

Enterprise Architecture Views and Viewpoints in ArchiMate - Reference

Source: ArchiMate 2.1 Specification, chapter 8, <http://pubs.opengroup.org/architecture/archimate2-doc/chap08.html>



Views and Viewpoints in ArchiMate

- In ArchiMate, architects and other stakeholders can define their own views on the enterprise architecture
- A viewpoint in ArchiMate is a selection of
 - ◆ a relevant subset of the ArchiMate concepts and their relationships
 - ◆ For each viewpoint one model kind exists
- A view is (a set of) models
 - ◆ representing a part of an architecture
 - ◆ using the concepts and relationships of the corresponding viewpoint

Examples of Stakeholders and Concerns

The following examples of stakeholders and concerns are mentioned in the ArchiMate specification as a basis for the specification of viewpoints:

End Users

- ◆ What are the consequences for his workplace?

Architect

- ◆ What is the consequence for the maintainability of a system?

Upper-level Management

- ◆ How can we ensure that our policies are followed in the development and operation of processes and systems?

Operational Manager – responsible for exploitation or maintenance

- ◆ Is there a need to adapt maintenance processes?

Project Manager – responsible for development of new applications

- ◆ What is the dependence of business processes on the applications to be built?

Developer

- ◆ What are the required modification with respect to the current situation?



Two-Dimensional Classification of Enterprise Architecture Viewpoints

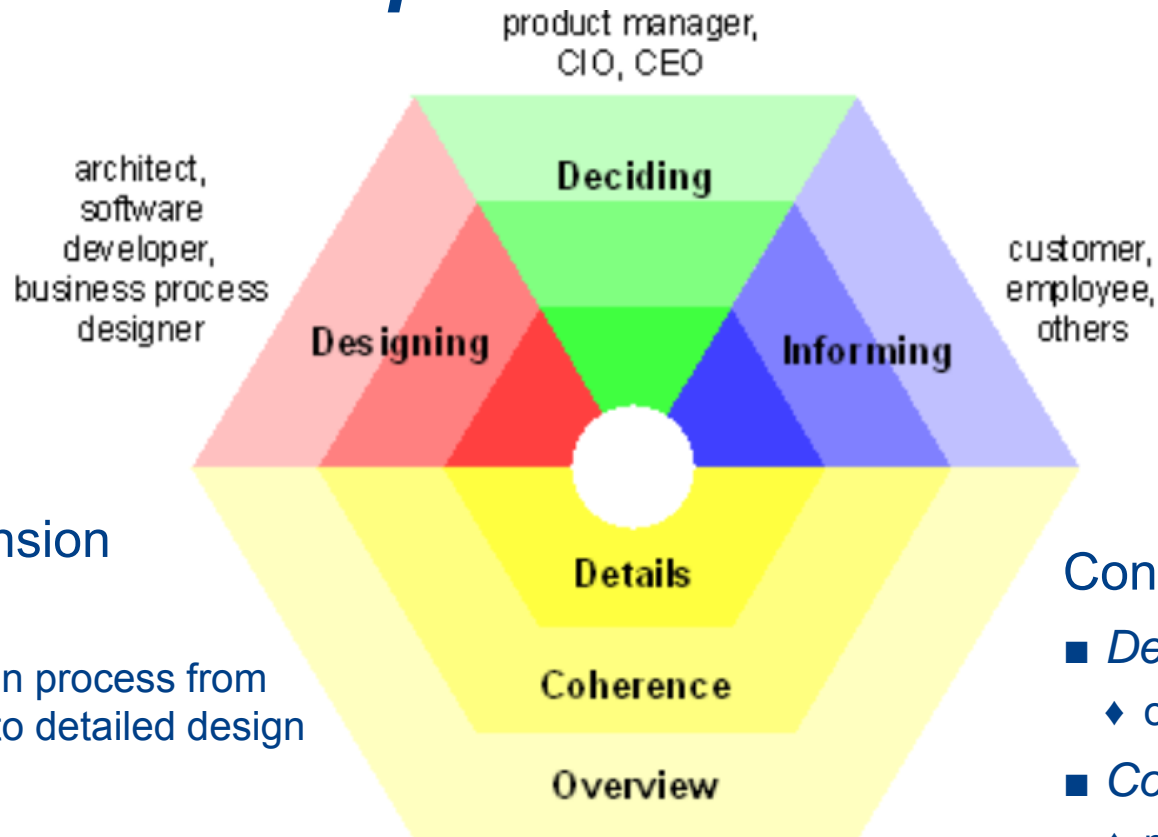

Purpose Dimension

■ *Designing*

- ◆ support design process from initial sketch to detailed design

■ *Deciding:*

- ◆ offering insight into cross-domain architecture relations

■ *Informing:*

- ◆ achieve understanding, obtain commitment, convince

Content Dimension

■ *Details:*

- ◆ one layer and one aspect

■ *Coherence:*

- ◆ multiple layers or multiple aspects
- ◆ focus on architecture relations between layers or aspects

■ *Overview:*

- ◆ both multiple layers and aspects



Viewpoints in ArchiMate

These viewpoints are suggested in ArchiMate based on experience:

1. Introductory Viewpoint
2. Organization Viewpoint
3. Actor Co-operation Viewpoint
4. Business Function Viewpoint
5. Business Process Viewpoint
6. Business Process Co-operation Viewpoint
7. Product Viewpoint
8. Application Behavior Viewpoint
9. Application Co-operation Viewpoint
10. Application Structure Viewpoint
11. Application Usage Viewpoint
12. Infrastructure Viewpoint
13. Infrastructure Usage Viewpoint
14. Implementation and Deployment Viewpoint
15. Information Structure Viewpoint
16. Service Realization Viewpoint
17. Layered Viewpoint
18. Landscape Map Viewpoint

Introductory Viewpoint

A subset of the full ArchiMate language using a simplified notation. Typically used at the start of a design trajectory, when not everything needs to be detailed or to avoid the impression that the architectural design is already fixed.

Introductory Viewpoint	
Stakeholders	Enterprise architects, managers
Concerns	Make design choices visible, convince stakeholders
Purpose	Designing, deciding, informing
Abstraction Level	Coherence, Overview, Detail
Layer	Business, Application, and Technology layers (see also Figure 4)
Aspects	Structure, behavior, information (see also Figure 4)

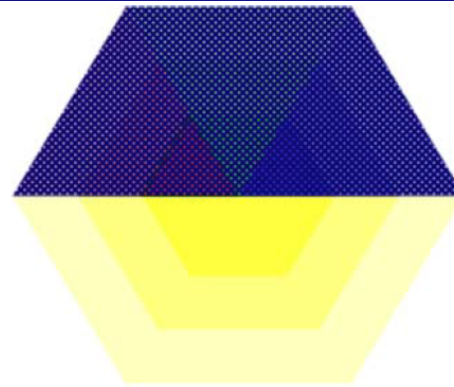

Concepts and Relationships:

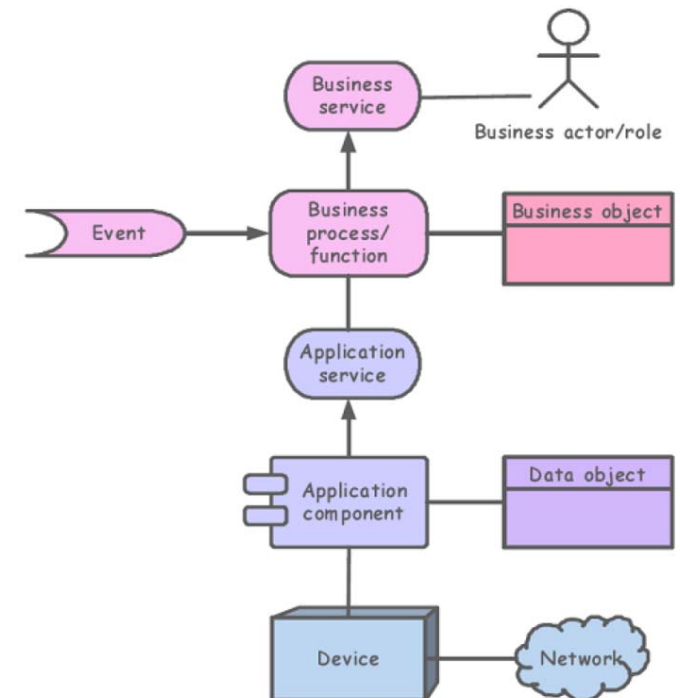

Example of a Model from the Introductory Viewpoint

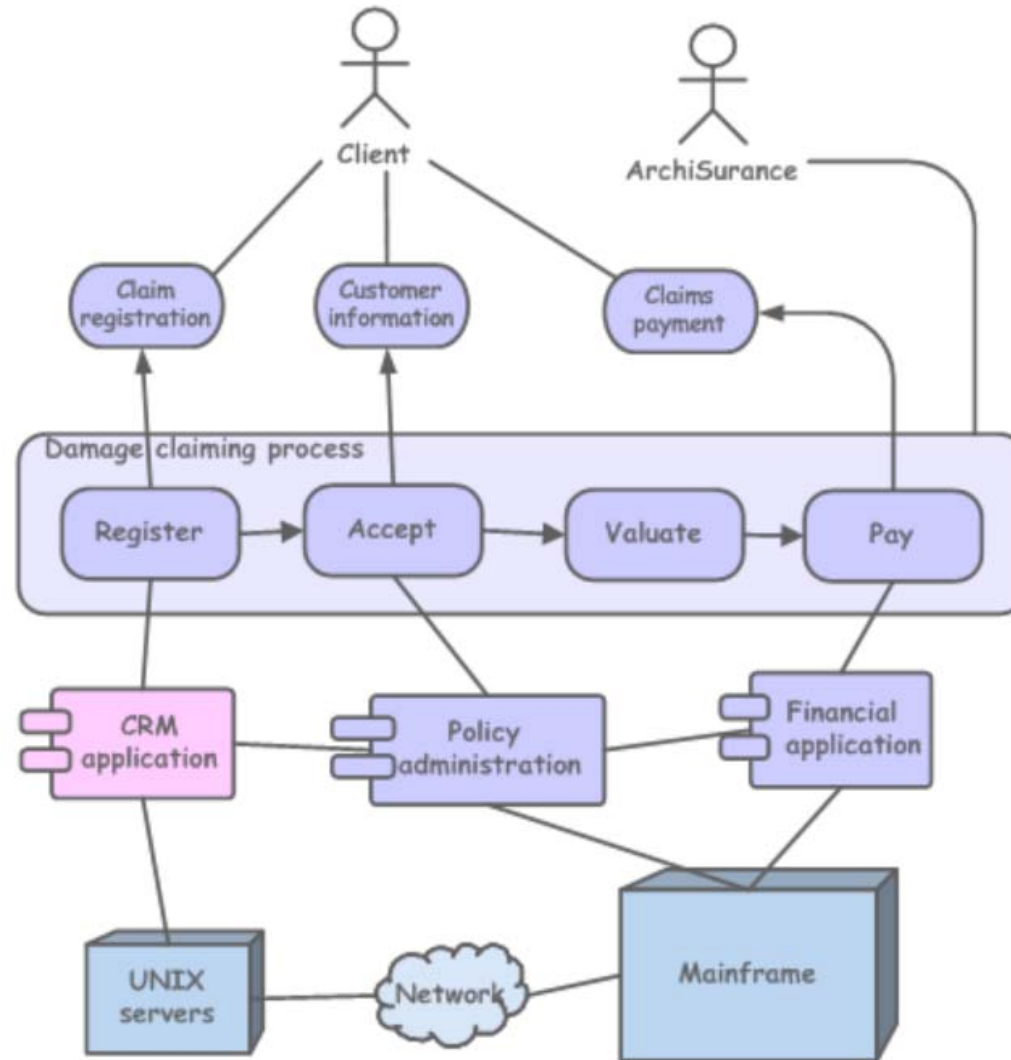

Organization Viewpoint

- (Internal) organization of a company, a department, a network of companies. Could be modeled as nested diagrams or as organizational charts.
- Useful in identifying competencies, authority, and responsibilities

Organization Viewpoint	
Stakeholders	Enterprise, process and domain architects, managers, employees, shareholders
Concerns	Identification of competencies, authority, and responsibilities
Purpose	Designing, deciding, informing
Abstraction Level	Coherence
Layer	Business layer (see also Figure 4)
Aspects	Structure (see also Figure 4)

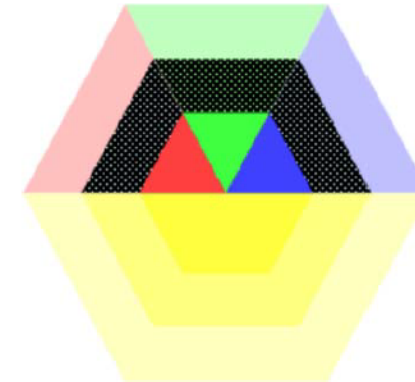

Concepts and Relations:

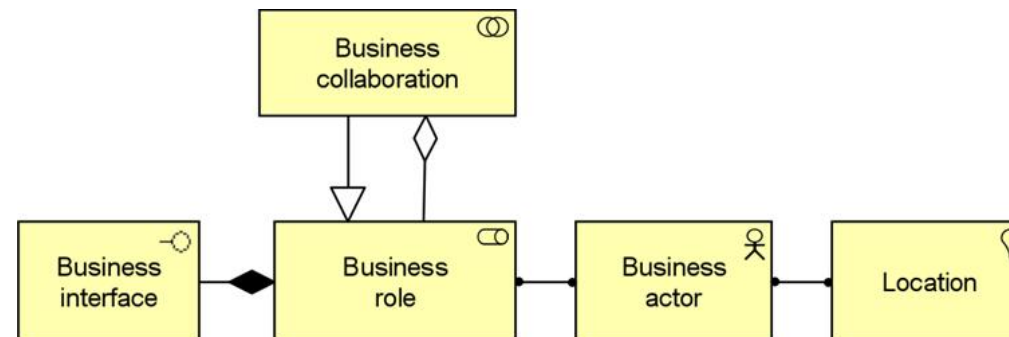

Example of a Model from the Organization Viewpoint

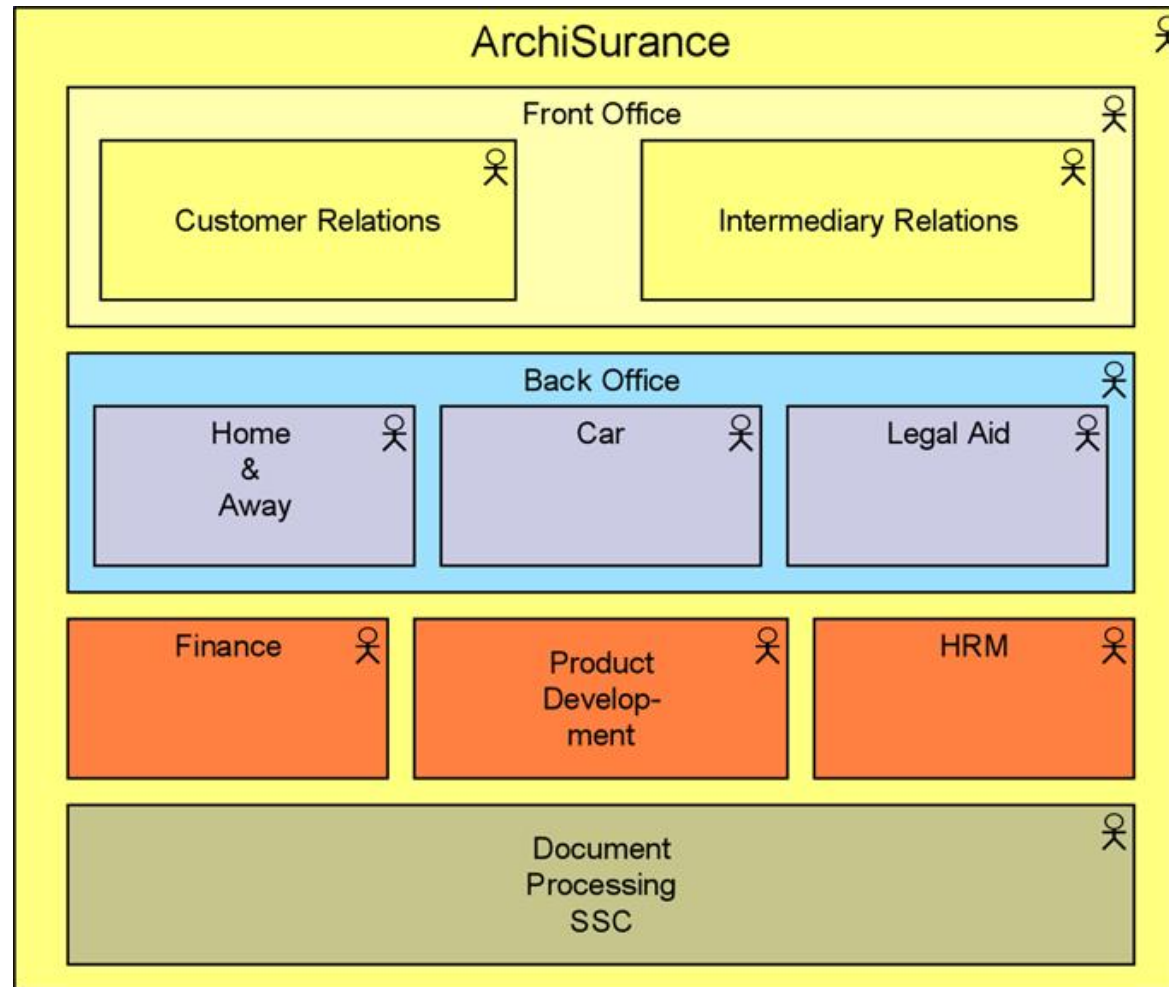

Actor Co-operation Viewpoint

- Extending the Organization Viewpoint with a focus on the relations of actors with each other and their environment
- Useful in determining external dependencies and collaborations; shows the value chain or network in which the actor operates.
- Can show how a number of co-operating business actors and/or application components together realize a business process

Actor Co-operation Viewpoint	
Stakeholders	Enterprise, process, and domain architects
Concerns	Relationships of actors with their environment
Purpose	Designing, deciding, informing
Abstraction Level	Detail
Layer	Business layer (application layer) (see also Figure 4)
Aspects	Structure, behavior (see also Figure 4)

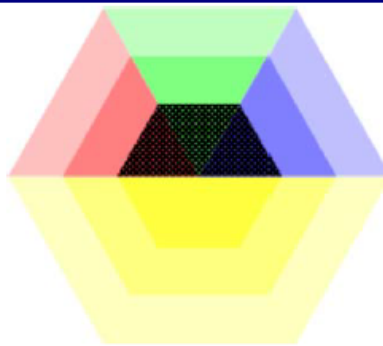

Concepts and Relationships:

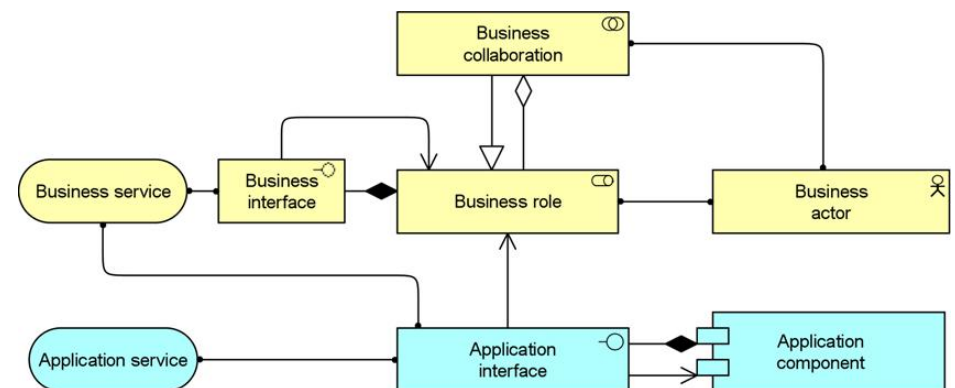

Example of a Model from the Actor Co-operation Viewpoint

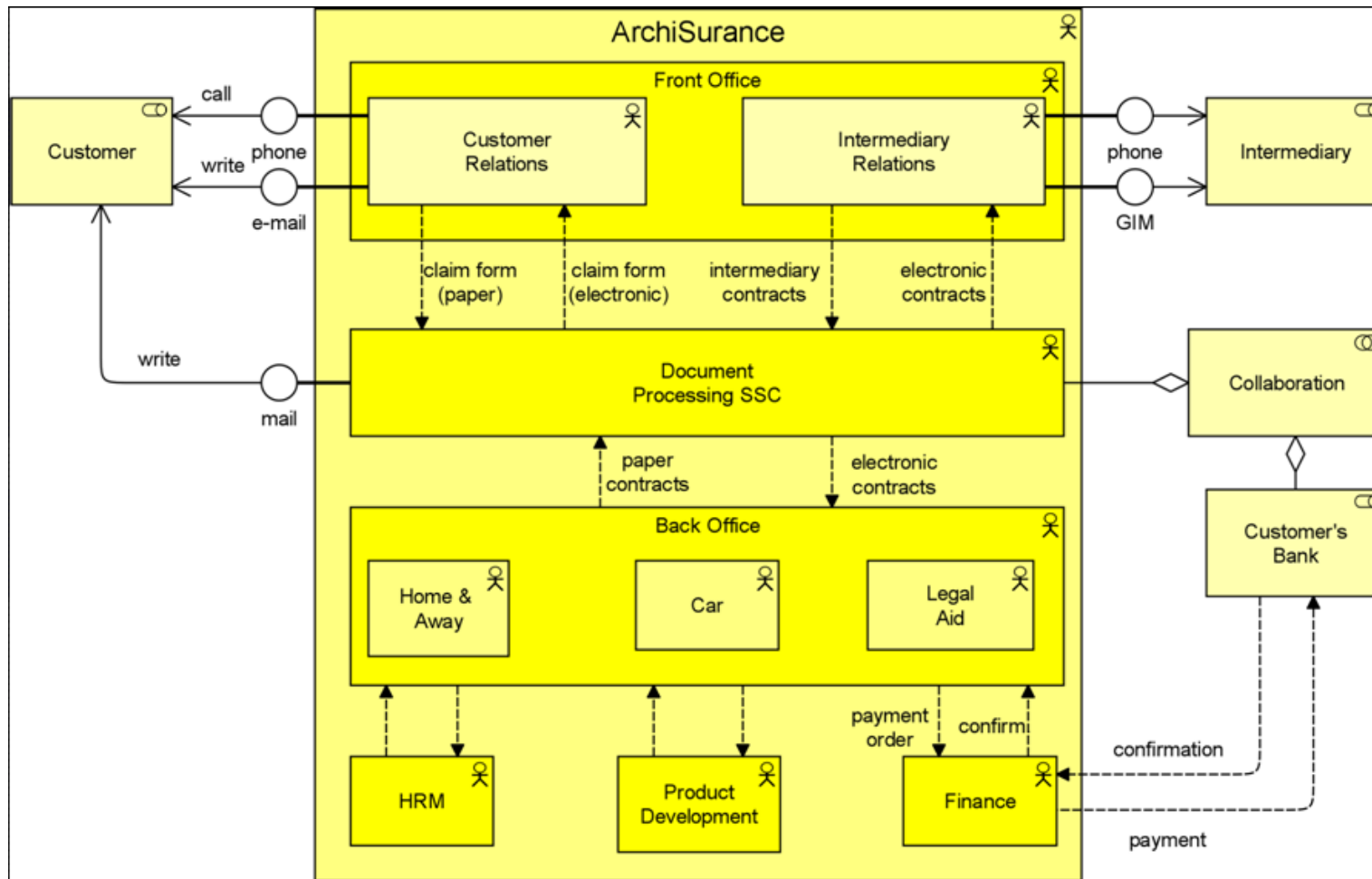

Business Function Viewpoint

- Shows the main business functions of an organisation and their relations in terms of flow of information, value or goods between them.

Business Function Viewpoint		
Stakeholders	Enterprise, process, and domain architects	
Concerns	Identification of competencies, identification of main activities, reduction of complexity	
Purpose	Designing	
Abstraction Level	Coherence	
Layer	Business layer (see also Figure 4)	
Aspects	Behavior, structure (see also Figure 4)	

Concepts and Relationships:

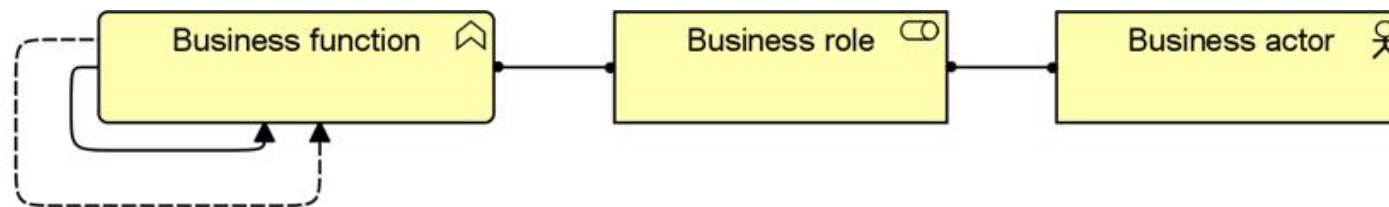

Example of a Model from the Business Function Viewpoint

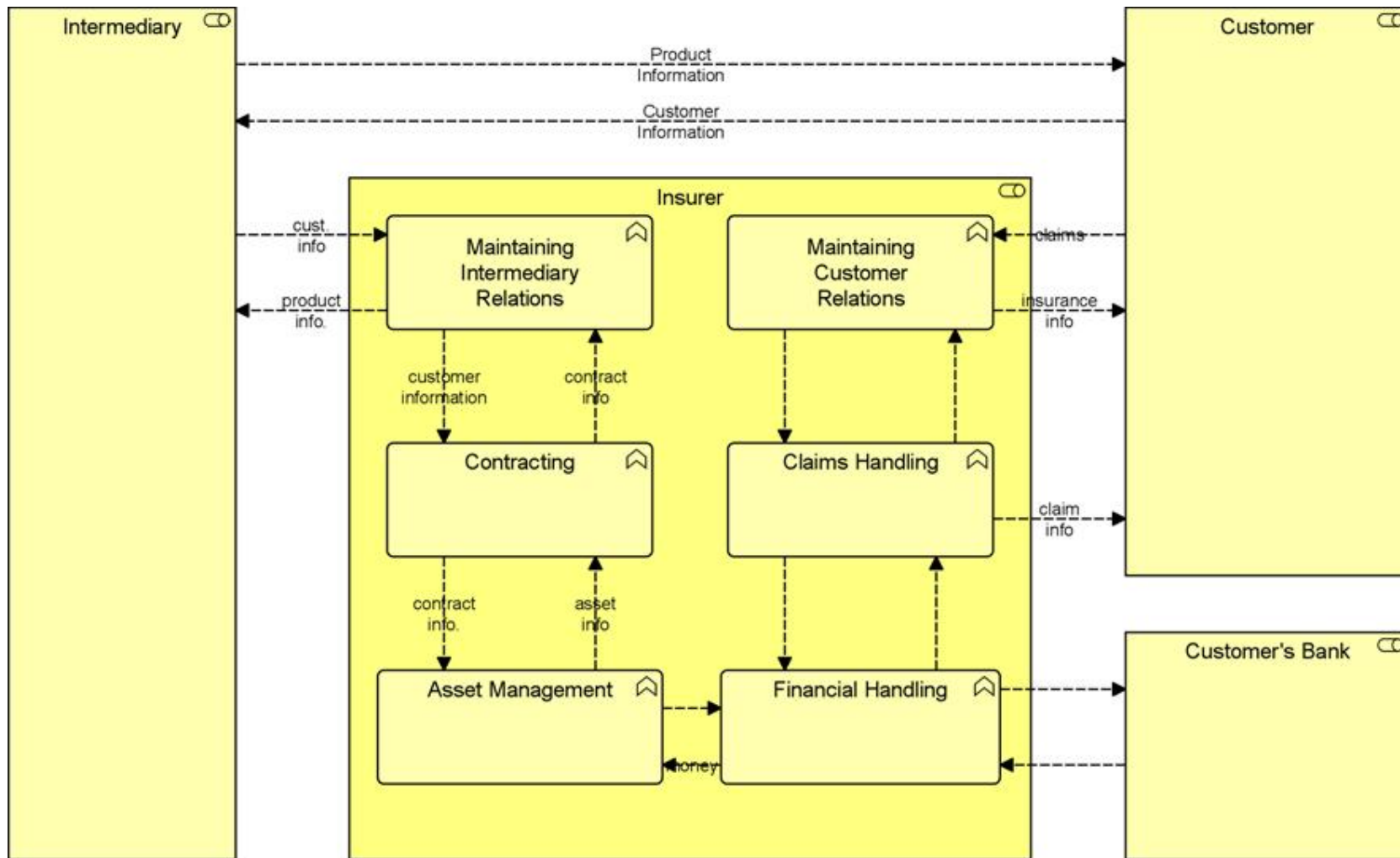

Business Process Viewpoint

Structure and composition of one or more business processes and directly related concepts like products, roles, and information

Business Process Viewpoint		
Stakeholders	Process and domain architects, operational managers	
Concerns	Structure of business processes, consistency and completeness, responsibilities	
Purpose	Designing	
Abstraction Level	Detail	
Layer	Business layer (see also Figure 4)	
Aspects	Behavior (see also Figure 4)	

Concepts and Relationships:

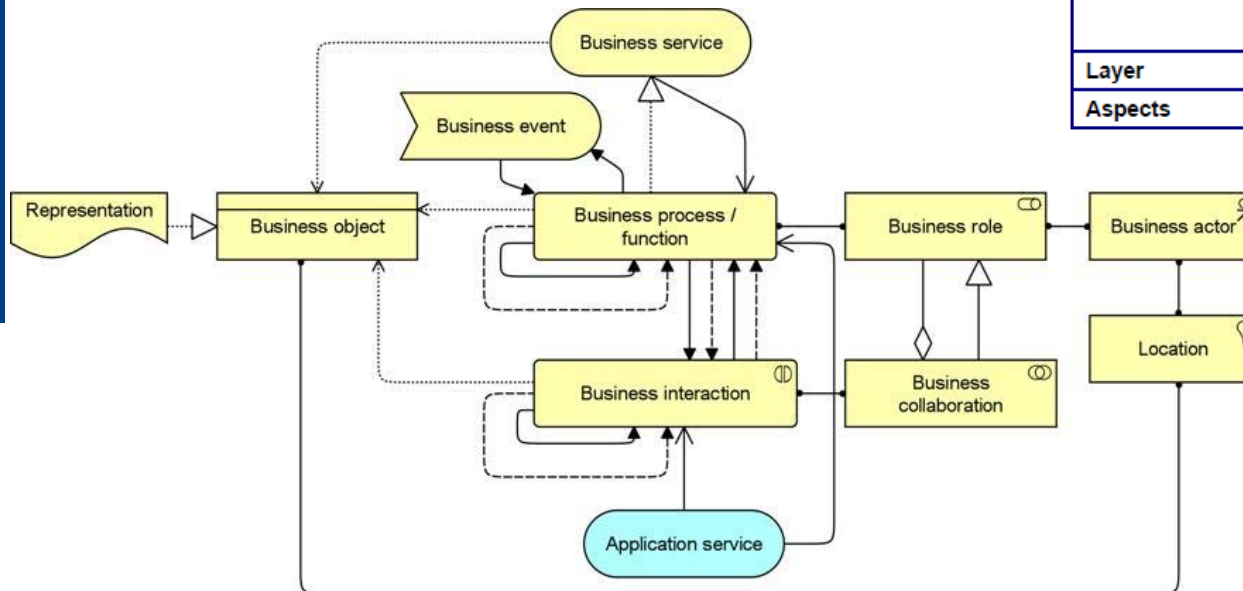

Example of a Model from the Business Process Viewpoint

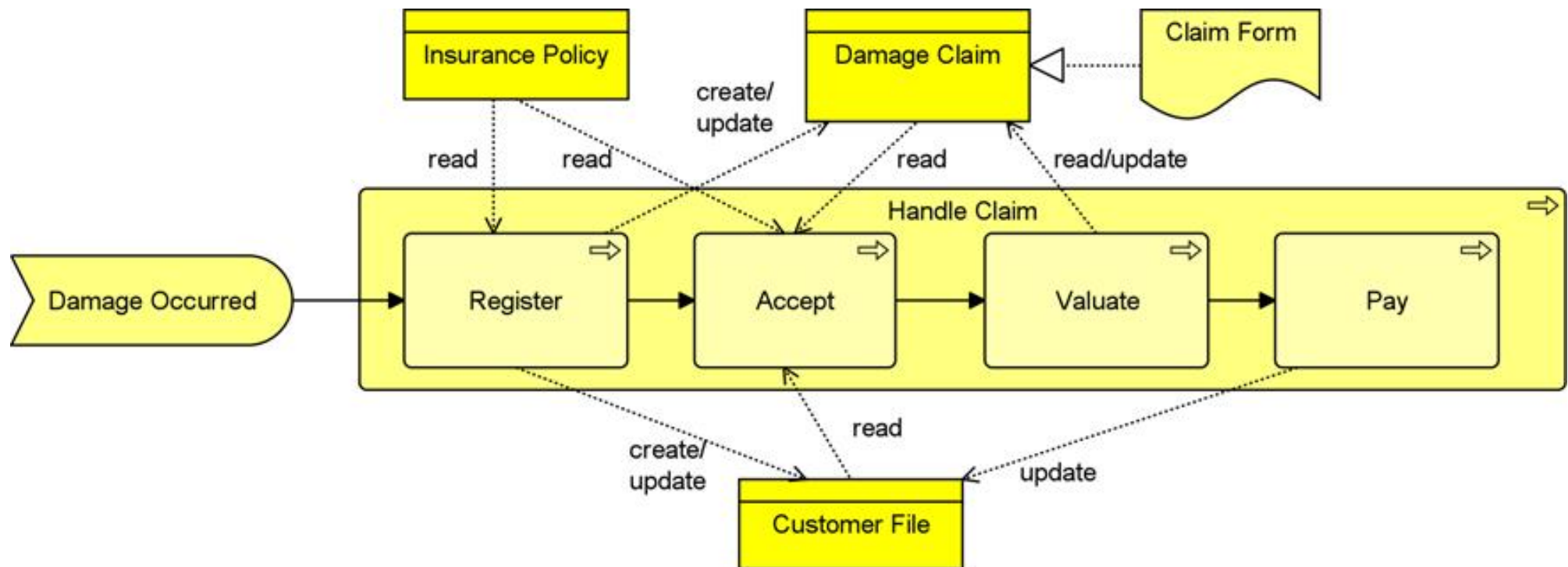

Business Process Co-operation Viewpoint

Relations of one or more business processes with each other and/or the environment.

Business Process Co-operation Viewpoint		
Stakeholders	Process and domain architects, operational managers	
Concerns	Dependencies between business processes, consistency and completeness, responsibilities	
Purpose	Designing, deciding	
Abstraction Level	Coherence	
Layer	Business layer, application layer (see also Figure 4)	
Aspects	Behavior (see also Figure 4)	

Concepts and Relationships:

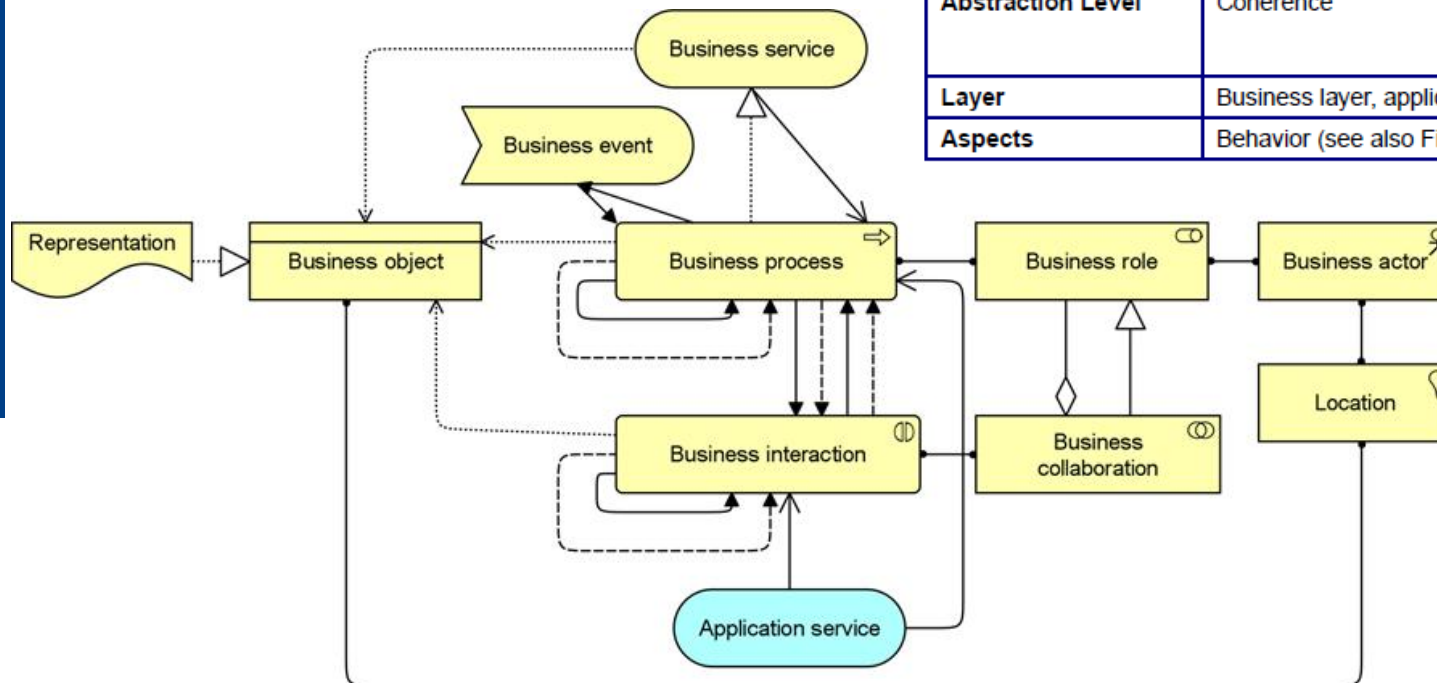

Example of a Model from the Business Process Co-operation Viewpoint

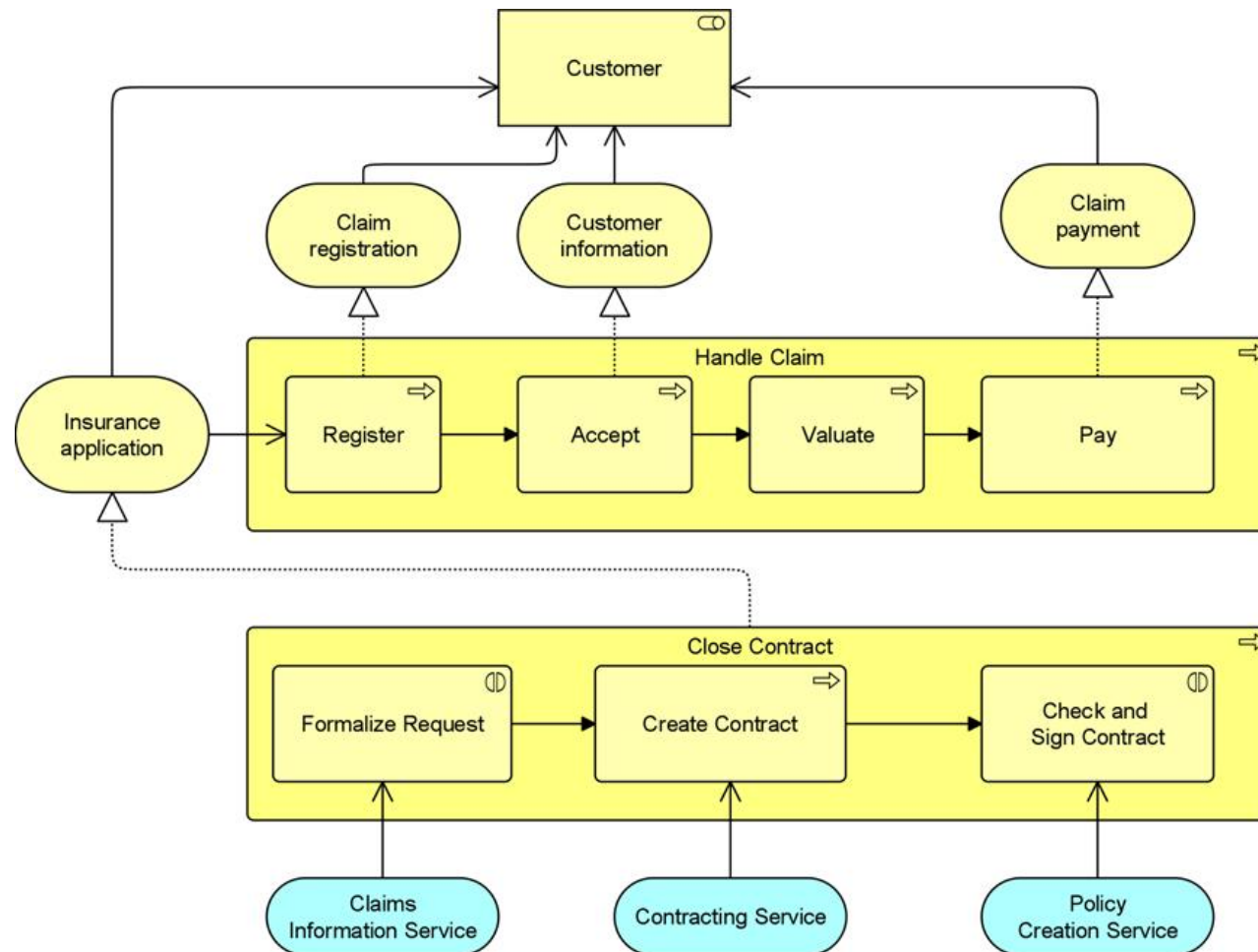

Product Viewpoint

Composition of products, the associated contract(s) or agreements, and the products' value to customers and other external parties..

Concepts and Relationships:

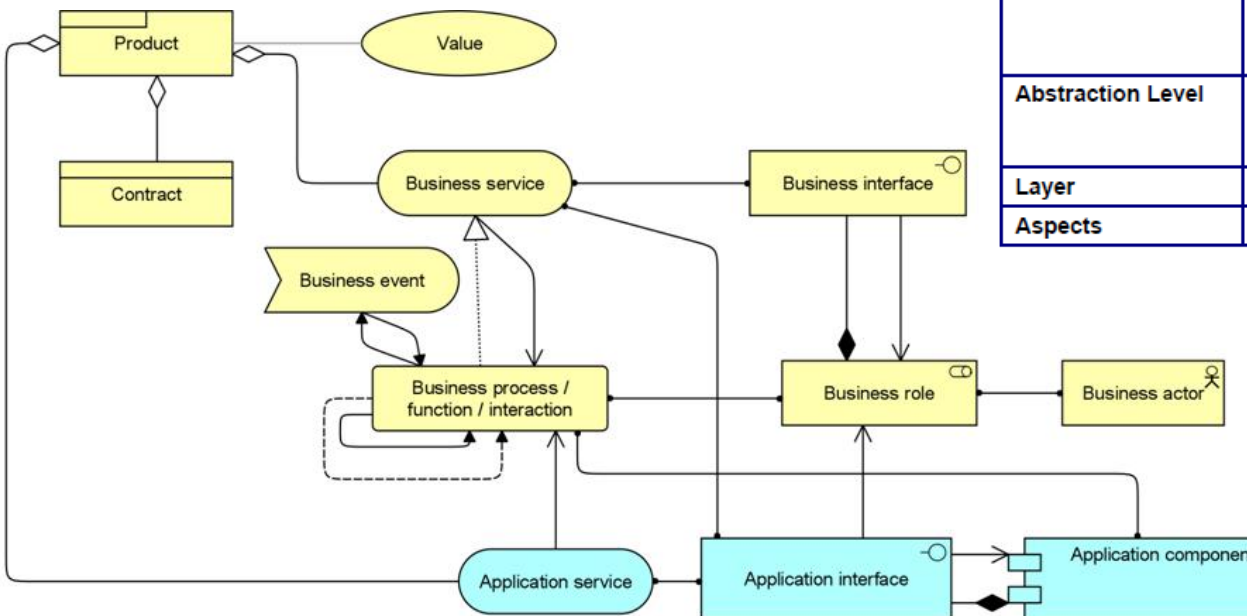

Product Viewpoint	
Stakeholders	Product developers, product managers, process and domain architects
Concerns	Product development, value offered by the products of the enterprise
Purpose	Designing, deciding
Abstraction Level	Coherence
Layer	Business layer, application layer (see also Figure 4)
Aspects	Behavior, information (see also Figure 4)

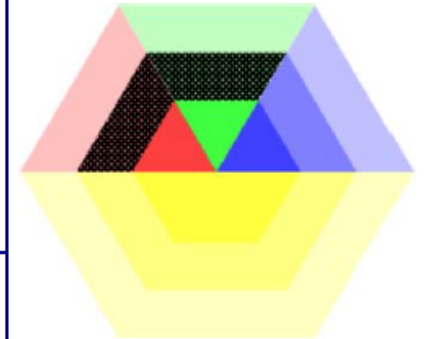

Example of a Model from the Product Viewpoint

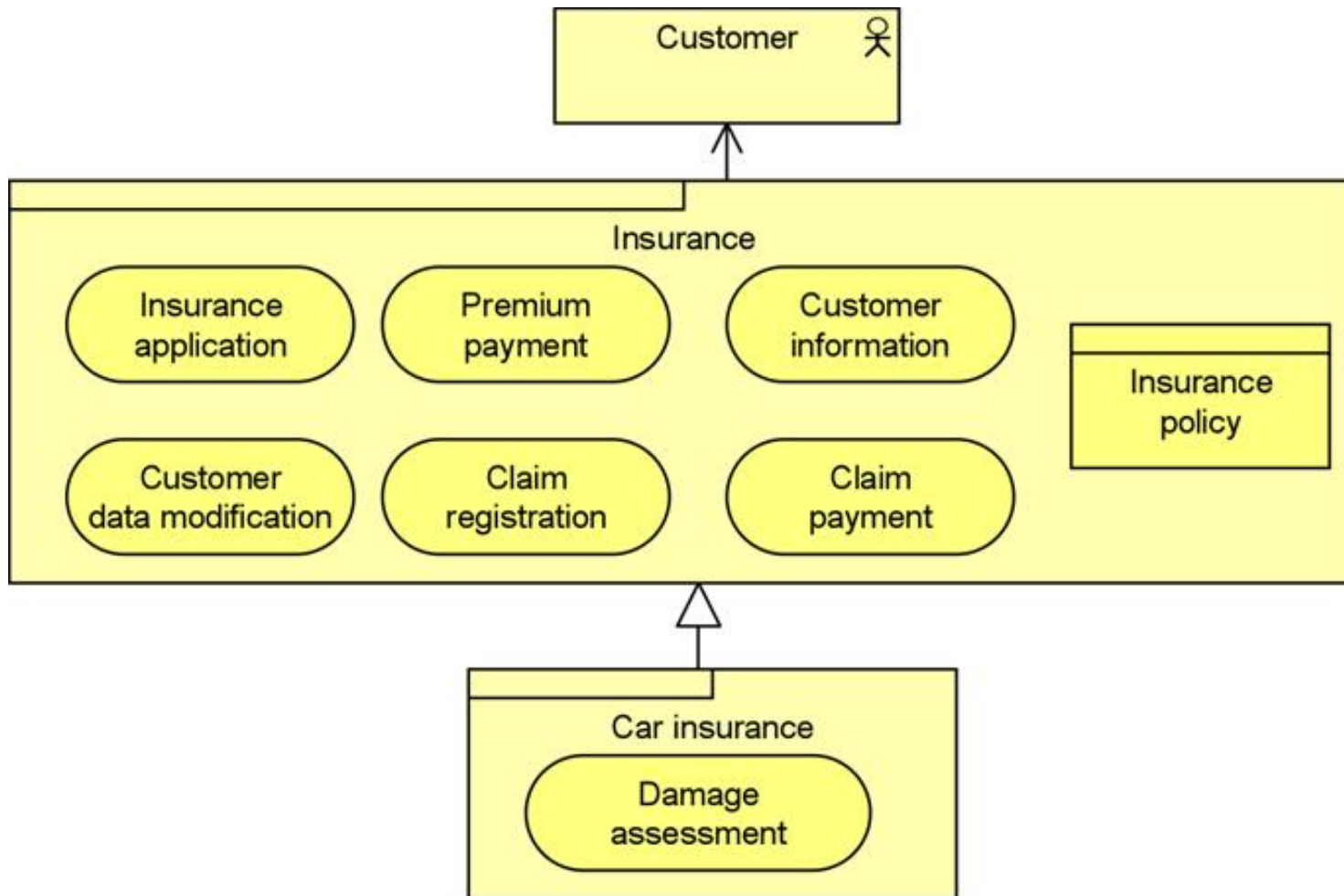

Application Behavior Viewpoint

Internal behavior of an application, e.g. as it realizes one or more services

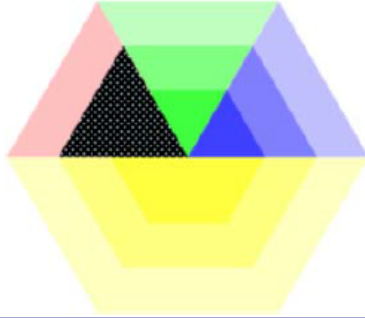
Application Behavior Viewpoint		
Stakeholders	Enterprise, process, application, and domain architects	
Concerns	Structure, relationships and dependencies between applications, consistency and completeness, reduction of complexity	
Purpose	Designing	
Abstraction Level	Coherence, details	
Layer	Application layer (see also Figure 4)	
Aspects	Information, behavior, structure (see also Figure 4)	

Concepts and Relationships:

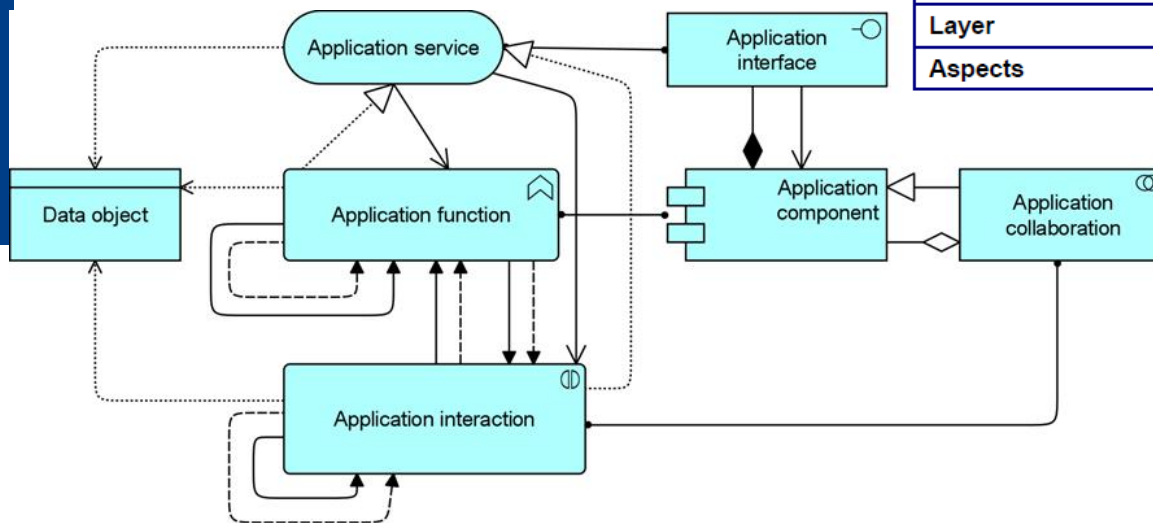

Example of a Model from the Application Behavior Viewpoint

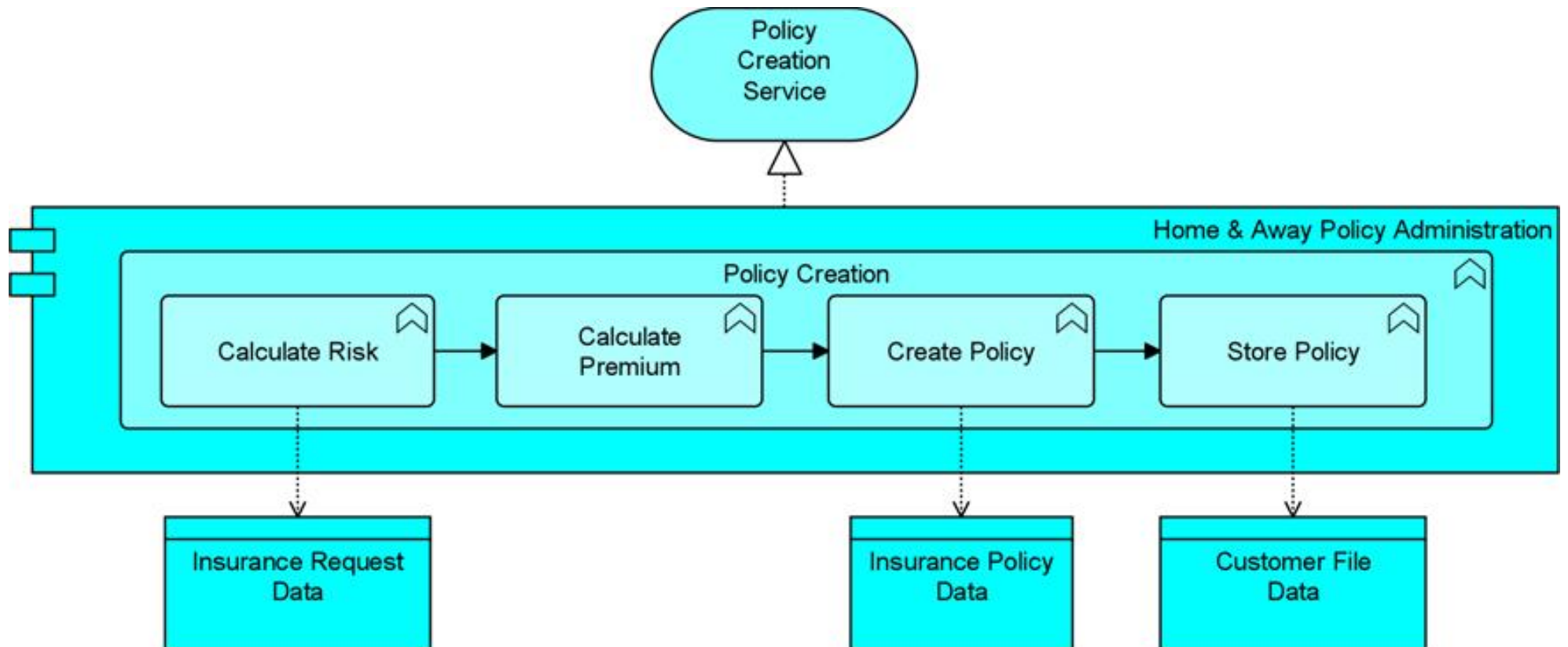

Example of a Model from the Application Co-operation Viewpoint

Relations between applications components in terms of the information flows between them, or in terms of the services they offer and use.

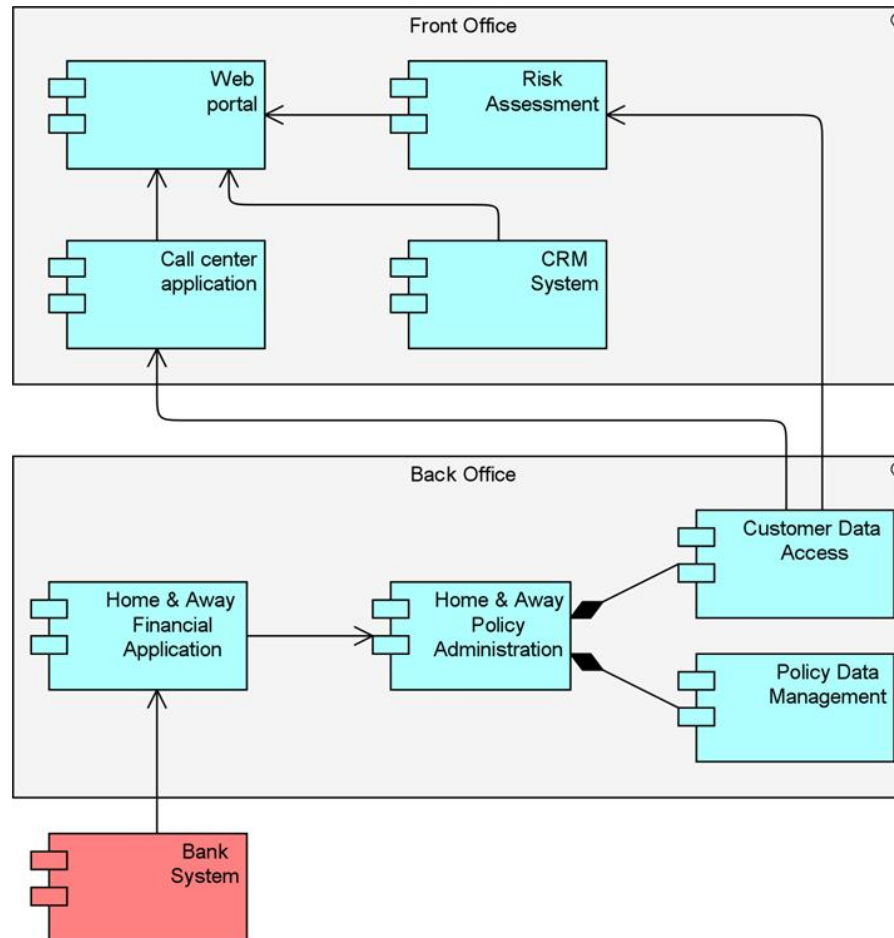

Application Structure Viewpoint

Structure of one or more applications or components. This viewpoint is useful in designing or understanding the main structure of applications or components and the associated data

Application Structure Viewpoint	
Stakeholders	Enterprise, process, application, and domain architects
Concerns	Application structure, consistency and completeness, reduction of complexity
Purpose	Designing
Abstraction Level	Details
Layer	Application layer (see also Figure 4)
Aspects	Structure, information (see also Figure 4)

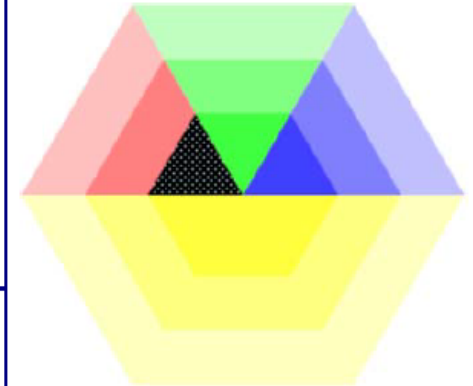

Concepts and Relationships:

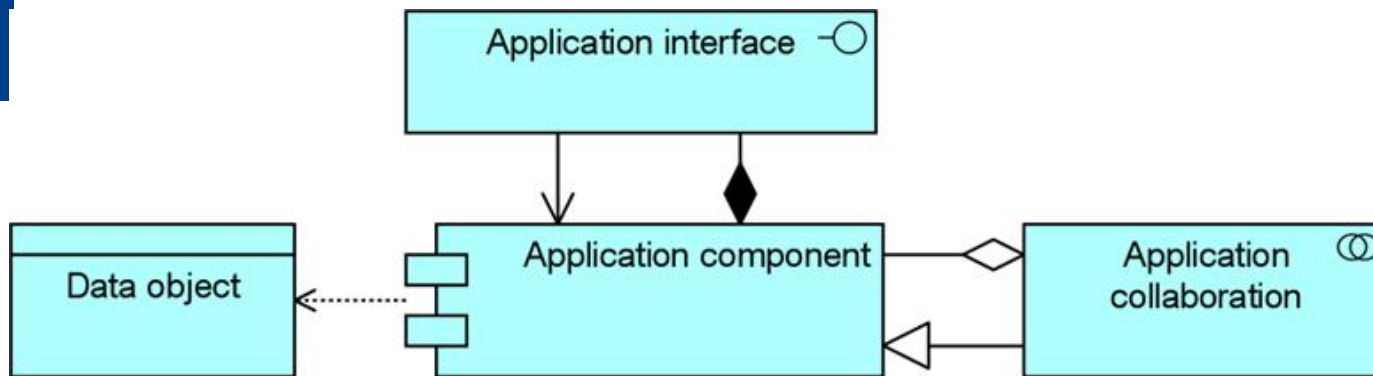

Example of a Model from the Application Structure Viewpoint

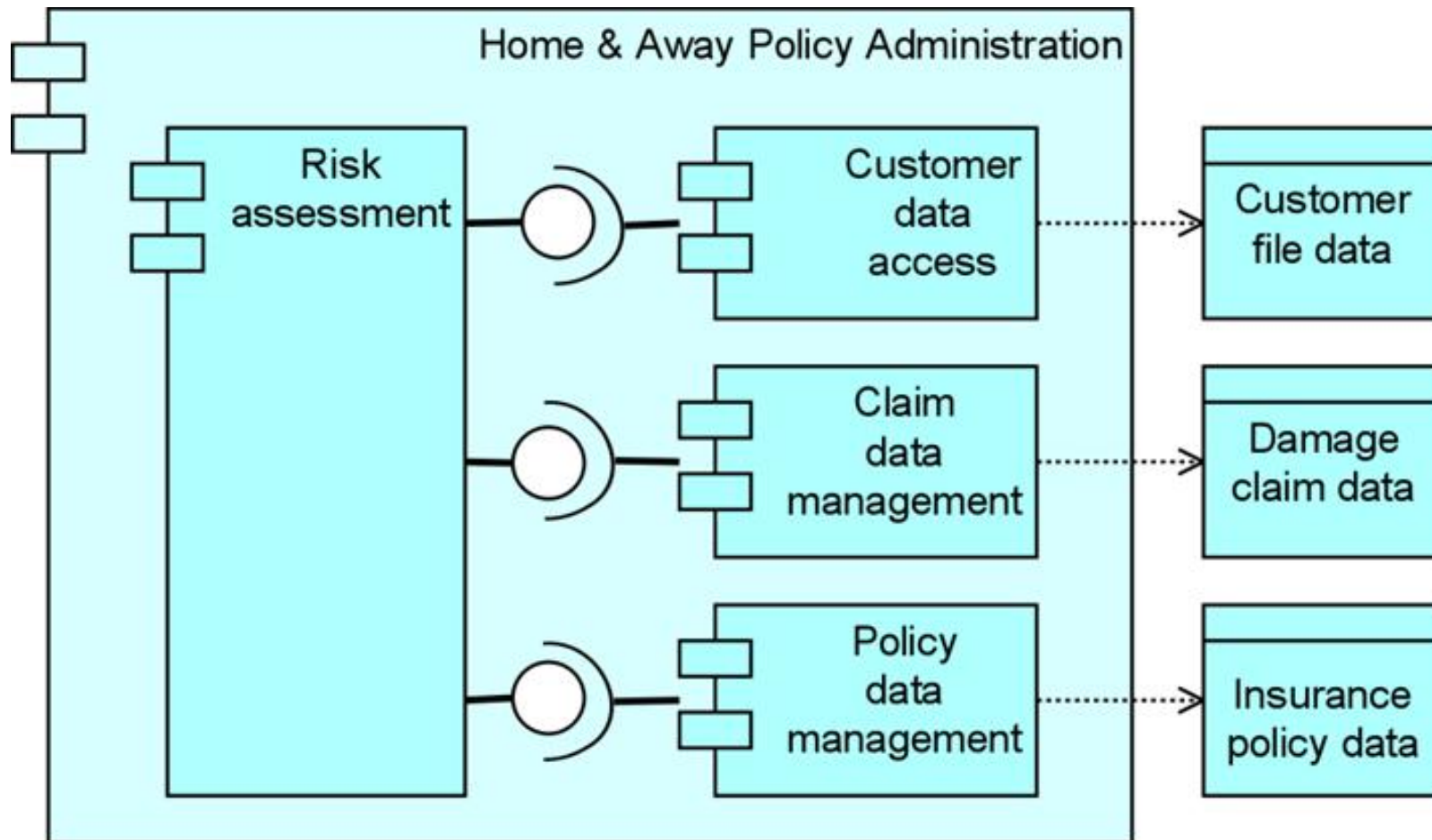

Application Usage Viewpoint

Describes how applications are used to support one or more business processes, and how they are used by other applications

Concepts and Relationships:

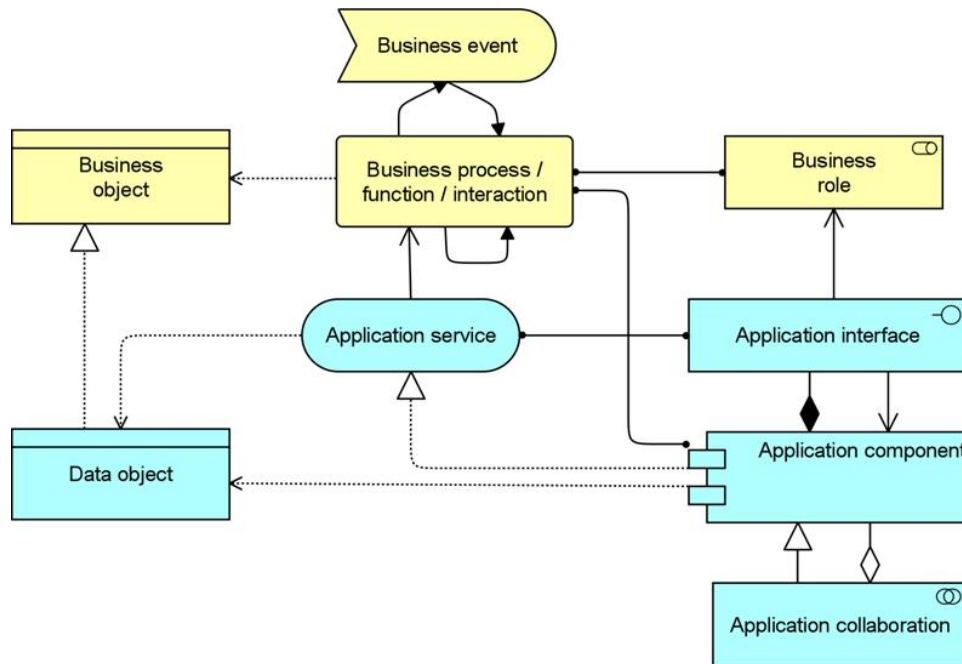

Application Usage Viewpoint	
Stakeholders	Enterprise, process, and application architects, operational managers
Concerns	Consistency and completeness, reduction of complexity
Purpose	Designing, deciding
Abstraction Level	Coherence
Layer	Business and application layers (see also Figure 4)
Aspects	Behavior, structure (see also Figure 4)

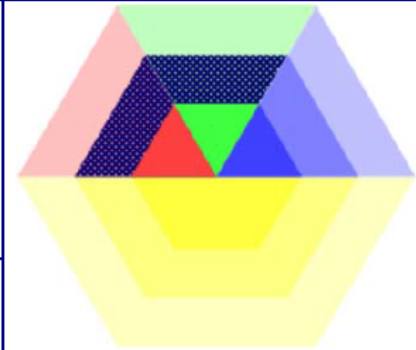

Example of a Model from the Application Usage Viewpoint

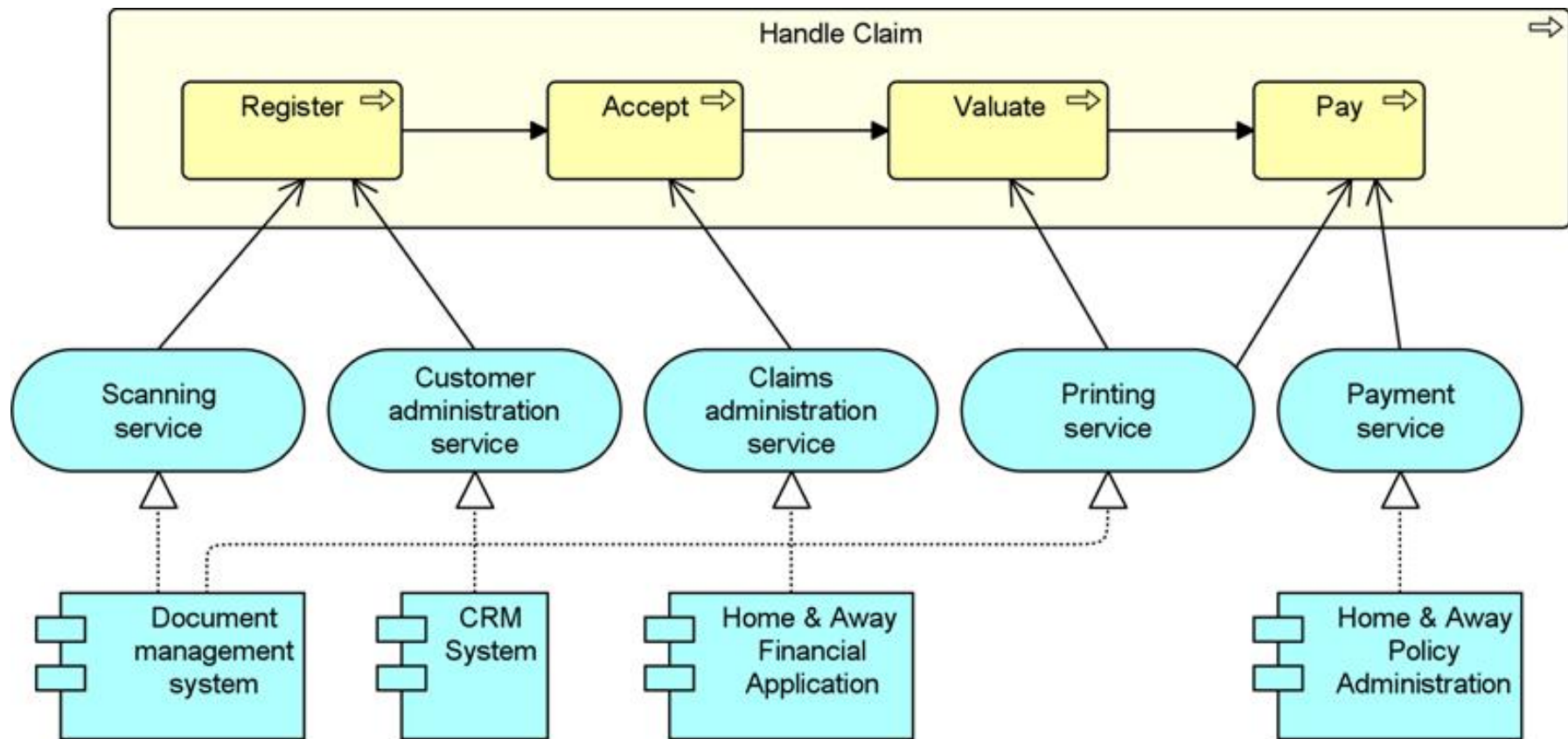

Infrastructure Viewpoint

Software and hardware infrastructure elements supporting the application layer, such as physical devices, networks, or system software (e.g., operating systems, databases, and middleware).

Infrastructure Viewpoint	
Stakeholders	Infrastructure architects, operational managers
Concerns	Stability, security, dependencies, costs of the infrastructure
Purpose	Designing
Abstraction Level	Details
Layer	Technology layer (see also Figure 4)
Aspects	Behavior, structure (see also Figure 4)

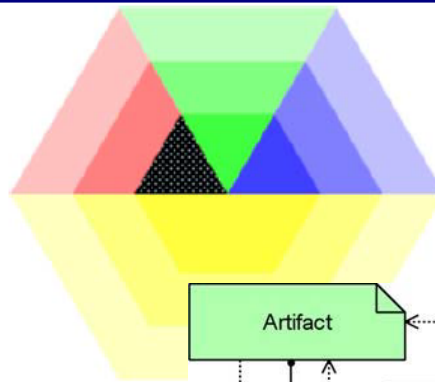

Concepts and Relationships:

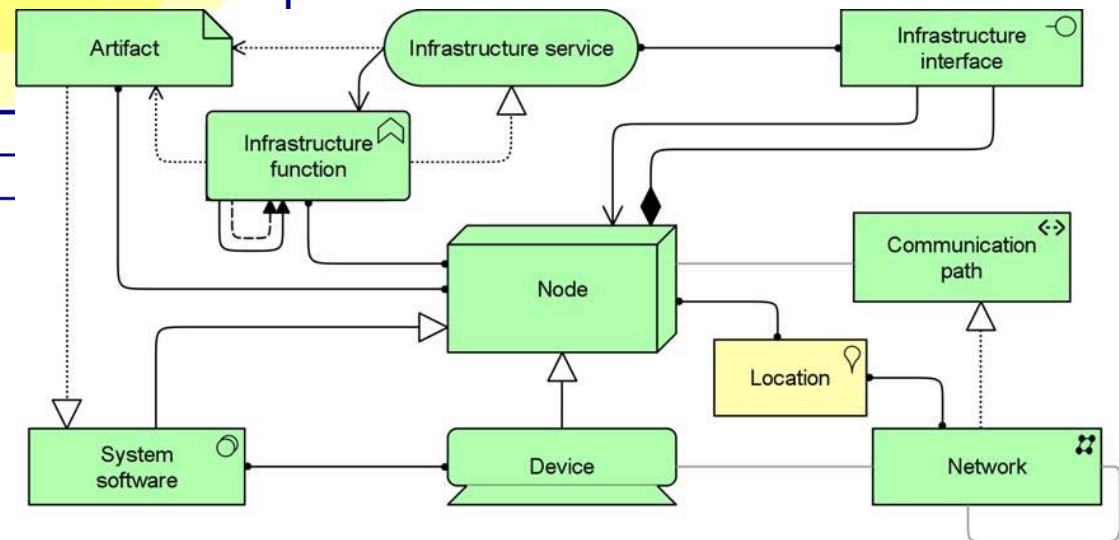

Example of a Model from the Infrastructure Viewpoint

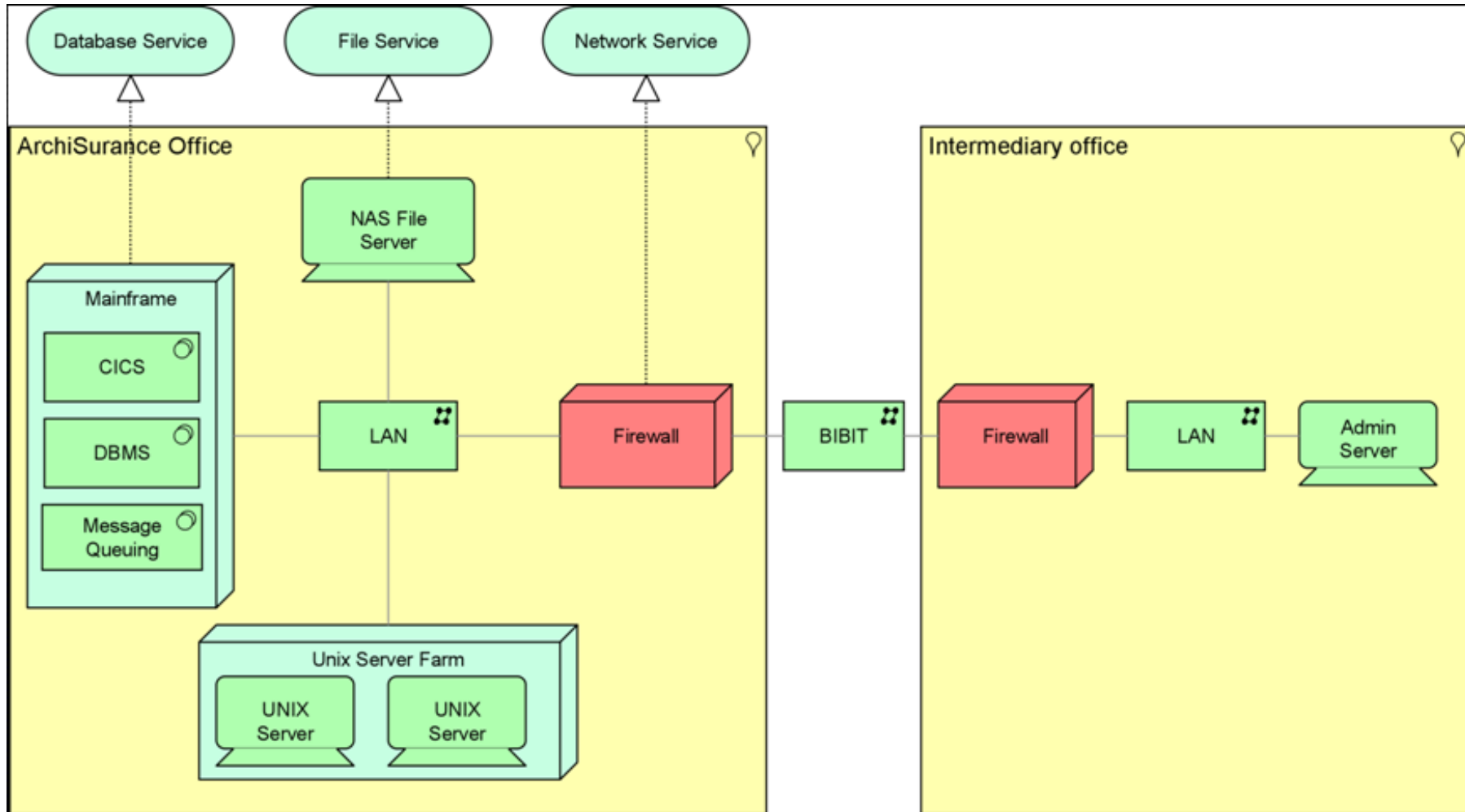

Infrastructure Usage Viewpoint

How applications are supported by the software and hardware infrastructure: the infrastructure services are delivered by the devices; system software and networks are provided to the applications

Infrastructure Usage Viewpoint	
Stakeholders	Application, infrastructure architects, operational managers
Concerns	Dependencies, performance, scalability
Purpose	Designing
Abstraction Level	Coherence
Layer	Application and technology layers (see also Figure 4)
Aspects	Behavior, structure (see also Figure 4)

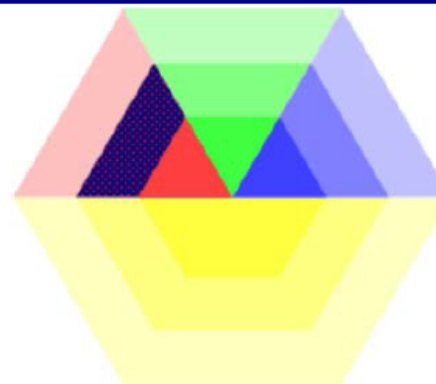

Concepts and Relationships:

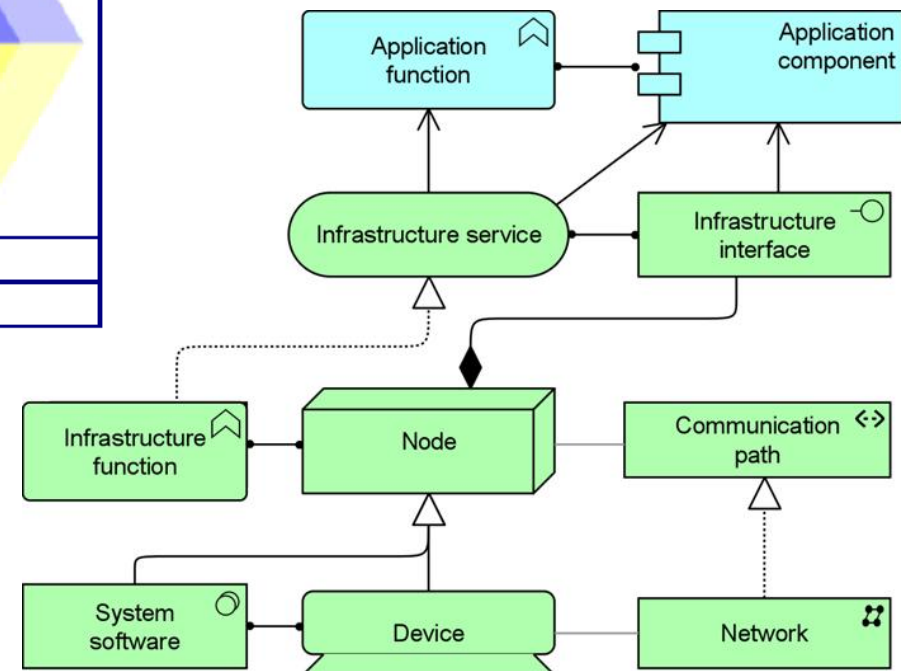

Example of a Model from the Infrastructure Usage Viewpoint

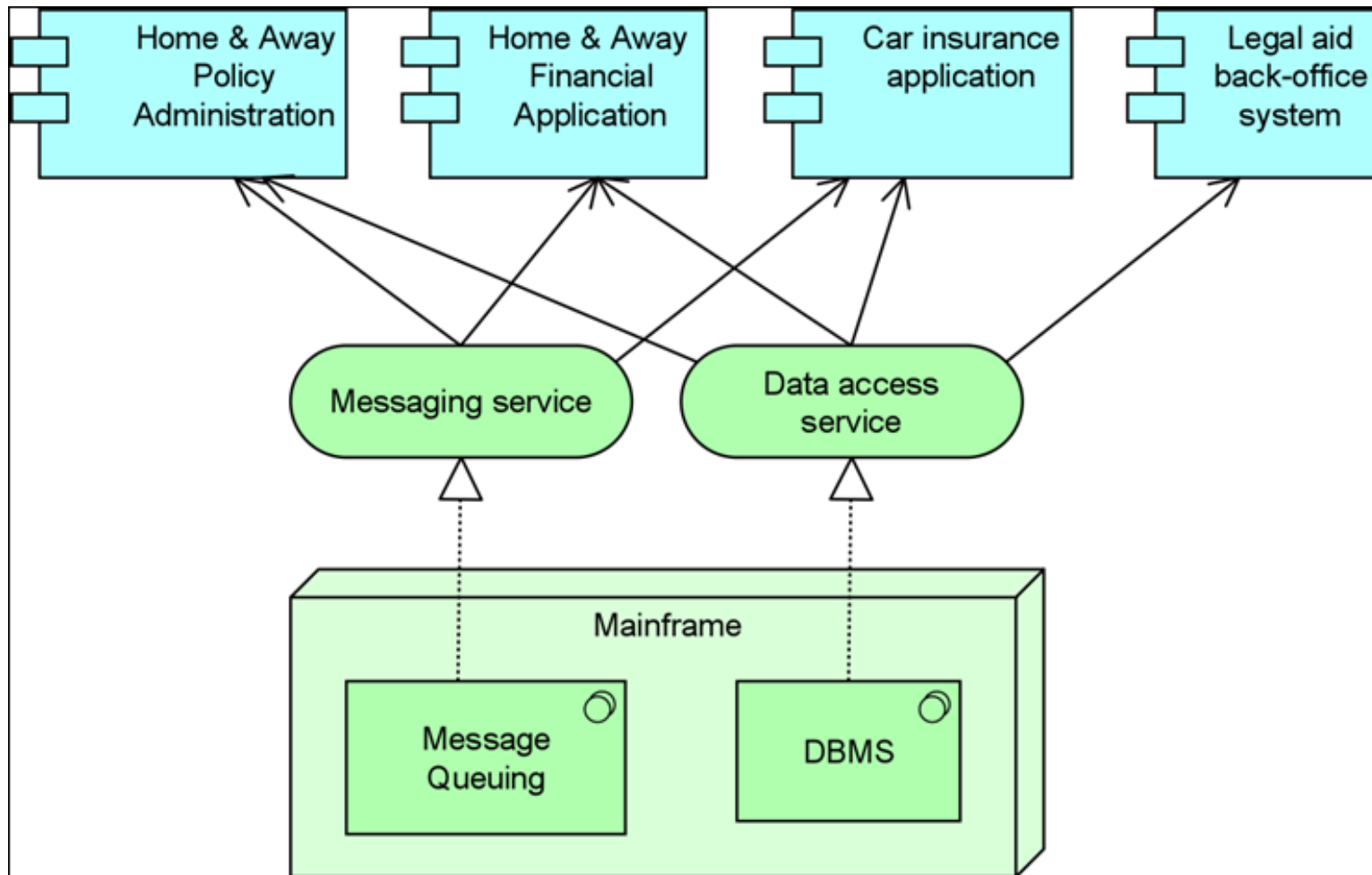

Implementation and Deployment Viewpoint

How one or more applications are realized on the infrastructure. This comprises the mapping of (logical) applications onto (physical) artifacts, such as Enterprise Java Beans, and the mapping of the information used by these applications onto the underlying storage infrastructure; e.g., database tables or other files.

Concepts and Relationships:

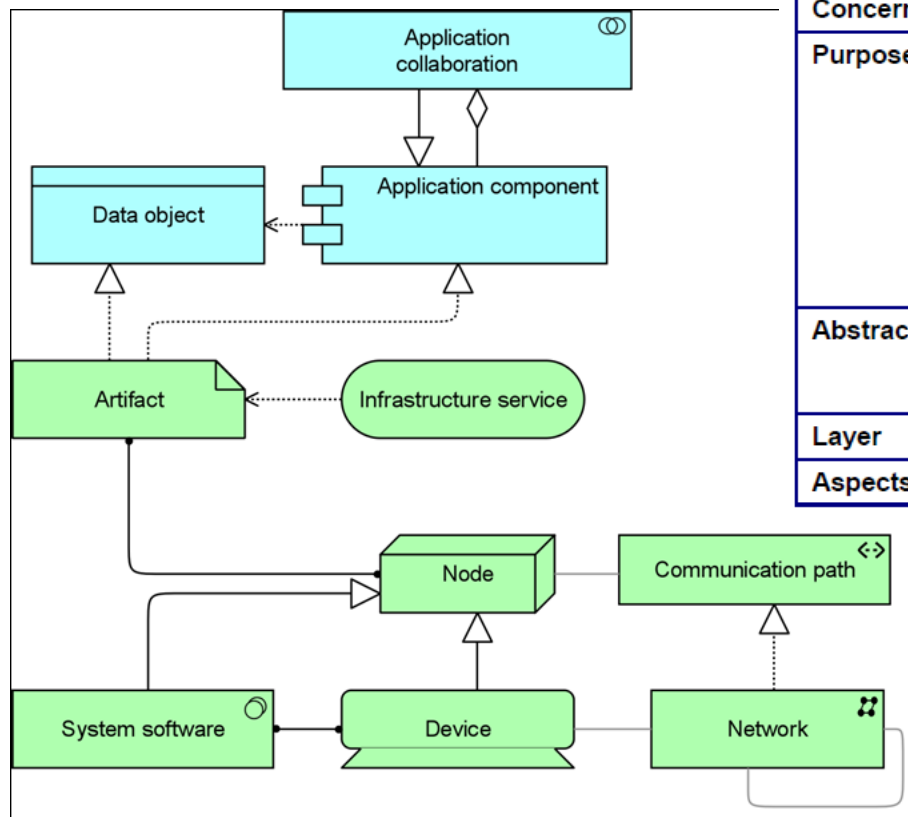

Implementation and Deployment Viewpoint	
Stakeholders	Application and infrastructure architects, operational managers
Concerns	Dependencies, security, risks
Purpose	Designing
Abstraction Level	Coherence
Layer	Application layer, technology layer (see also Figure 4)
Aspects	Information, behavior, structure (see also Figure 4)

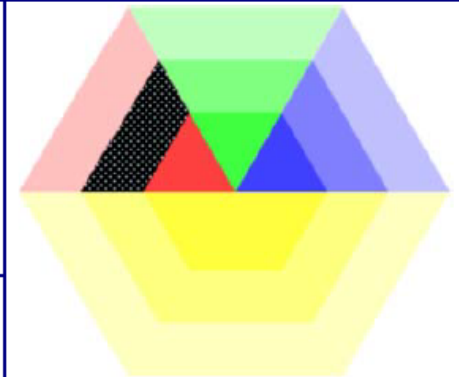

Example of a Model from the Implementation and Deployment Viewpoint

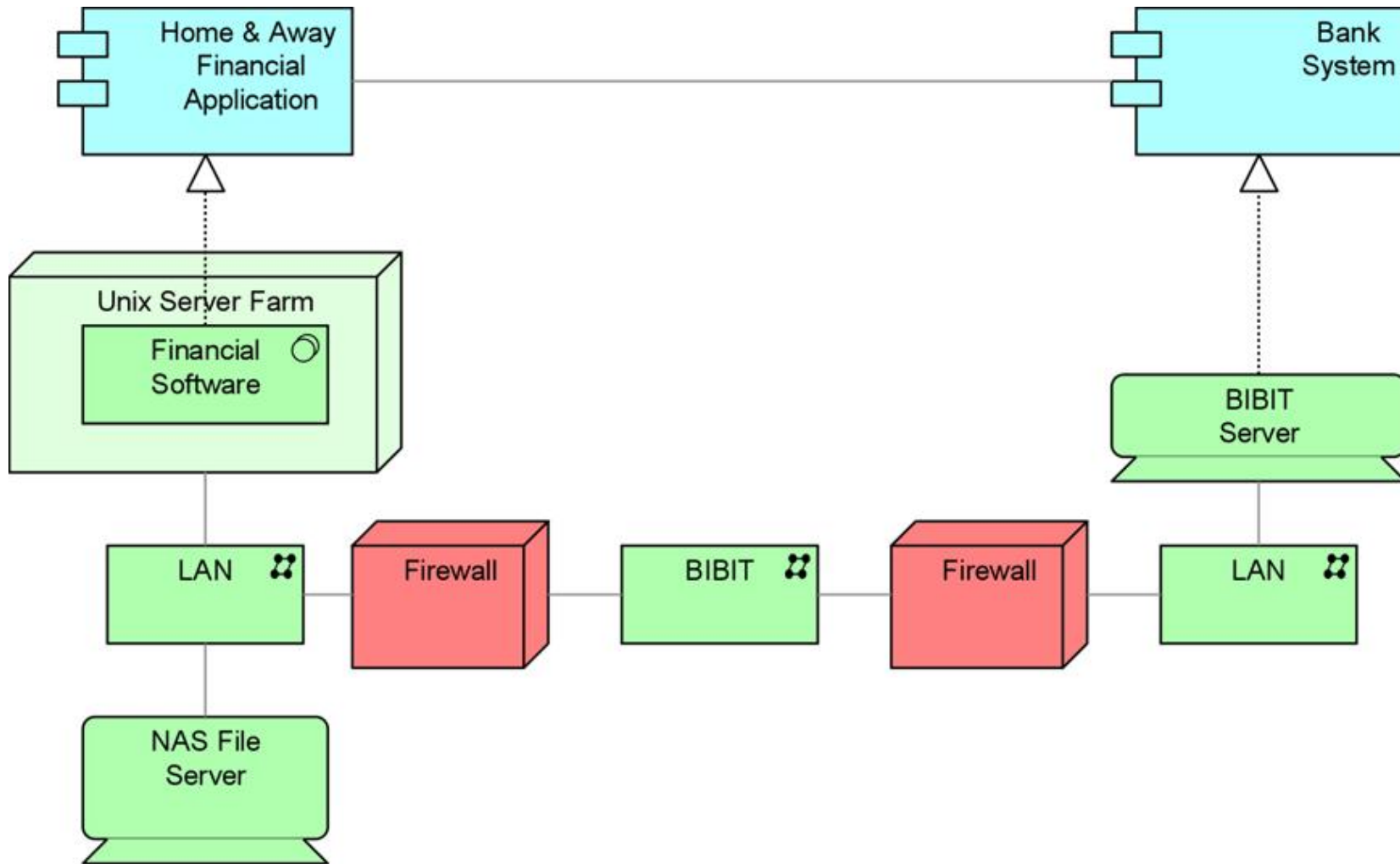

Information Structure Viewpoint

It shows the structure of the information used in the enterprise or in a specific business process or application, in terms of data types or (object-oriented) class structures. It is comparable to the traditional information models created in the development of almost any information system.

Information Structure Viewpoint	
Stakeholders	Domain and information architects
Concerns	Structure and dependencies of the used data and information, consistency and completeness
Purpose	Designing
Abstraction Level	Details
Layer	Business layer, application layer, technology layer (see also Figure 4)
Aspects	Information (see also Figure 4)

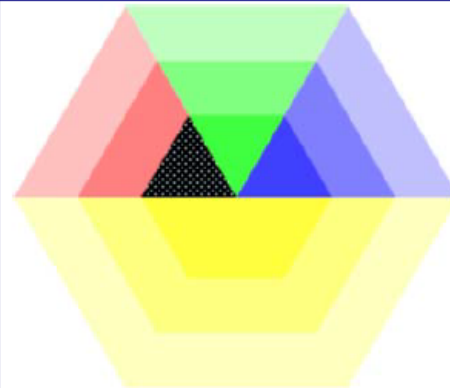

Concepts and Relationships:

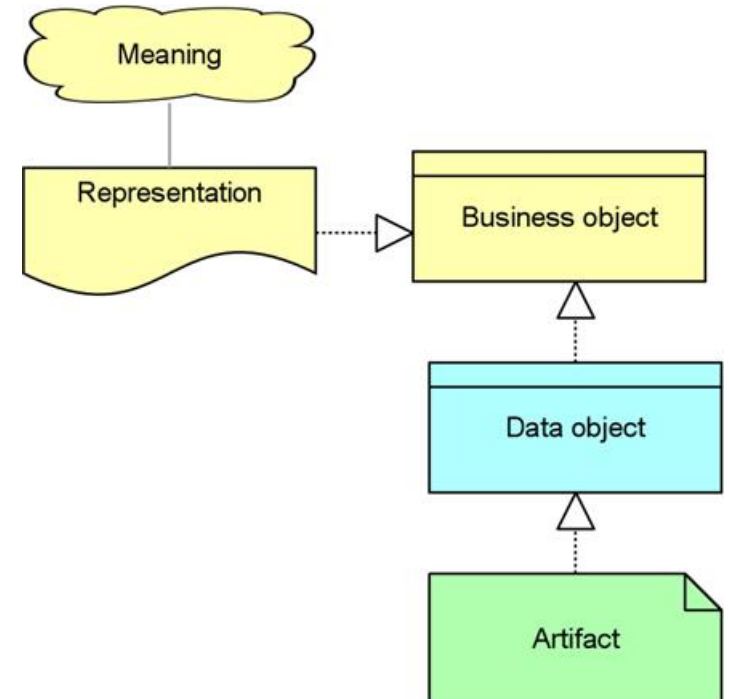

Example of a Model from the Information Structure Viewpoint

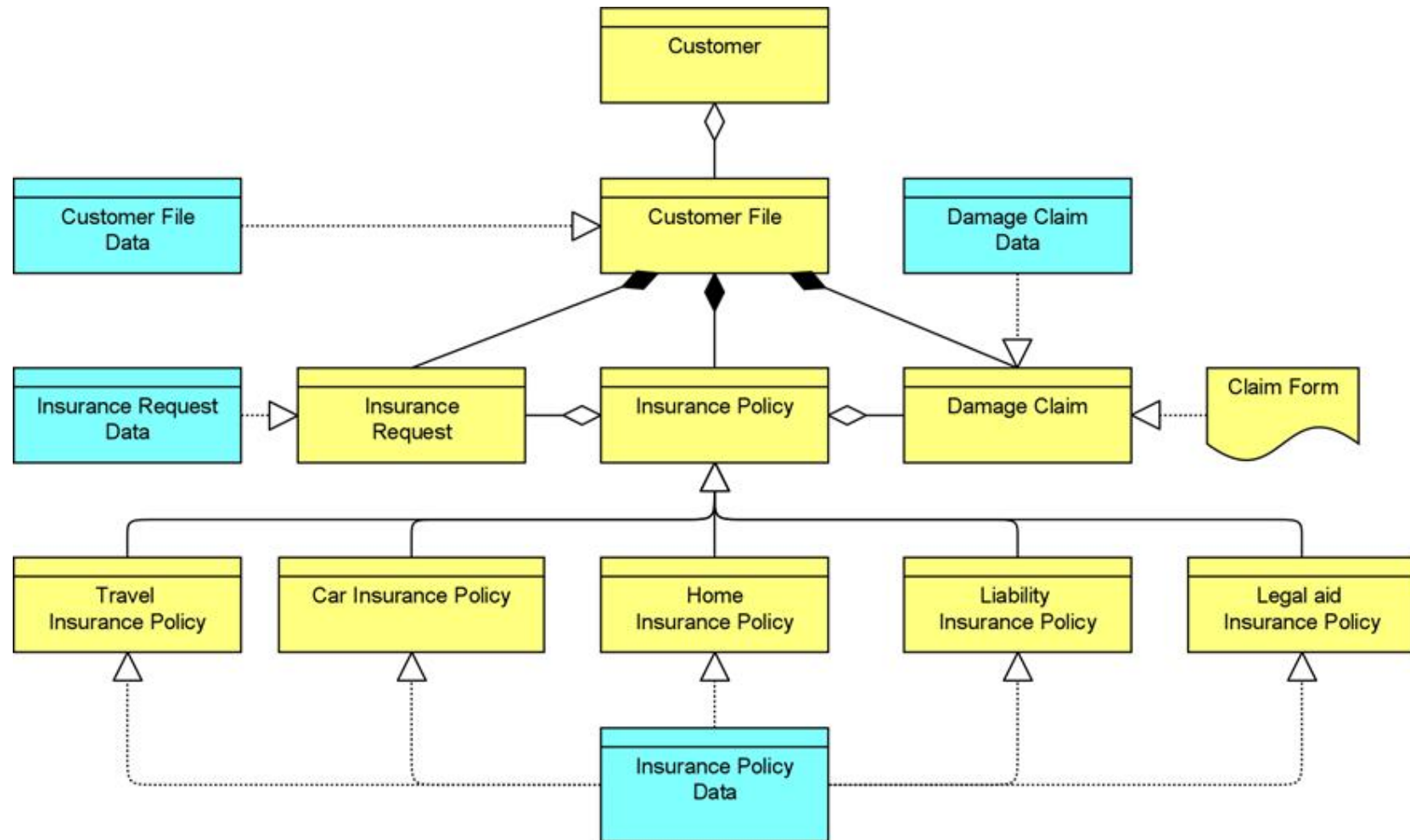

Service Realization Viewpoint

How one or more business services are realized by the underlying processes (and sometimes by application components). Thus, it forms the bridge between the business products viewpoint and the business process view.

Service Realization Viewpoint	
Stakeholders	Process and domain architects, product and operational managers
Concerns	Added-value of business processes, consistency and completeness, responsibilities
Purpose	Designing, deciding
Abstraction Level	Coherence
Layer	Business layer (application layer) (see also Figure 4)
Aspects	Behavior, structure, information (see also Figure 4)

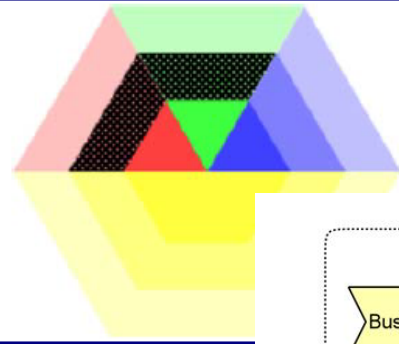

Concepts and Relationships:

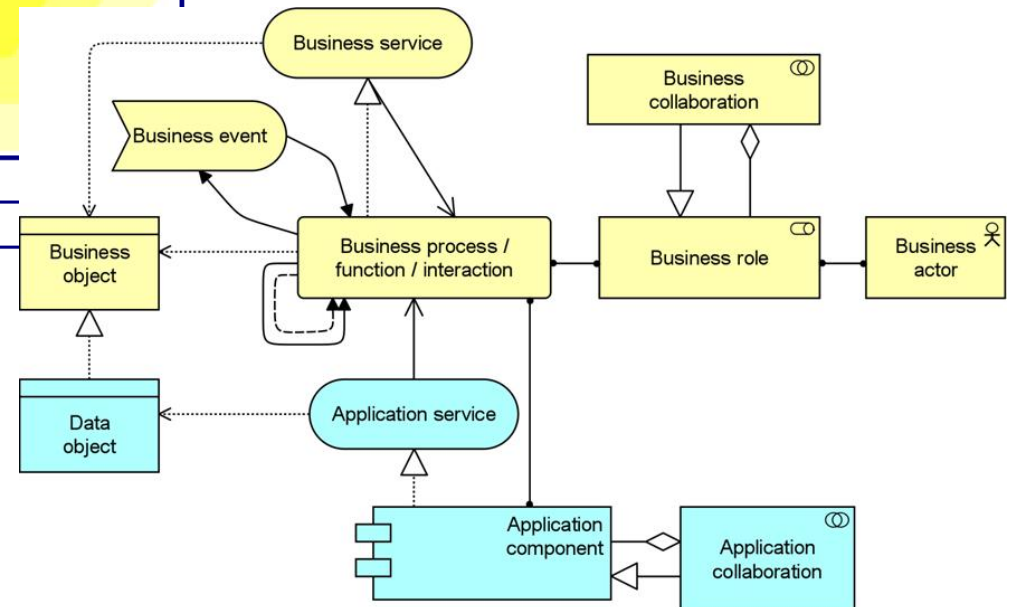

Example of a Model from the Service Realization Viewpoint

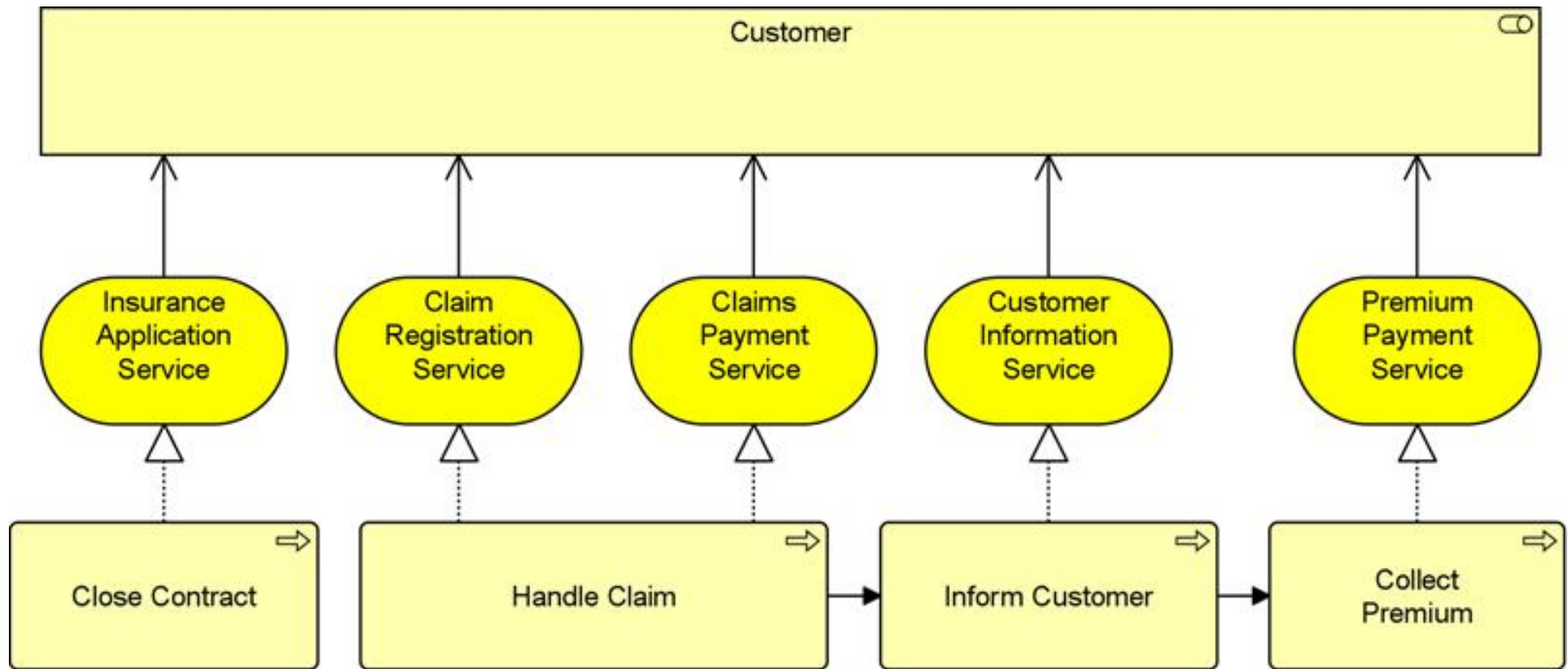

Layered Viewpoint

The Layered viewpoint pictures several layers and aspects of an enterprise architecture in one diagram.

The layers are the result of the use of the “grouping” relation for a natural partitioning of the entire set of objects and relations that belong to a model.

Each dedicated layer exposes, by means of the “realization” relation a layer of services, which are further on “used by” the next dedicated layer.

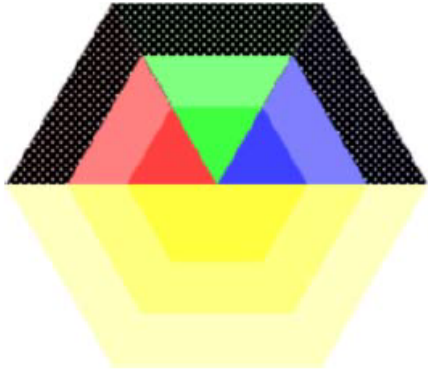
Layered Viewpoint		
Stakeholders	Enterprise, process, application, infrastructure, and domain architects	
Concerns	Consistency, reduction of complexity, impact of change, flexibility	
Purpose	Designing, deciding, informing	
Abstraction Level	Overview	
Layer	Business layer, application layer, technology layer (see also Figure 4)	
Aspects	Information, behavior, structure (see also Figure 4)	

Concepts and Relationships: **all**



Example of a Model from the Layered Viewpoint

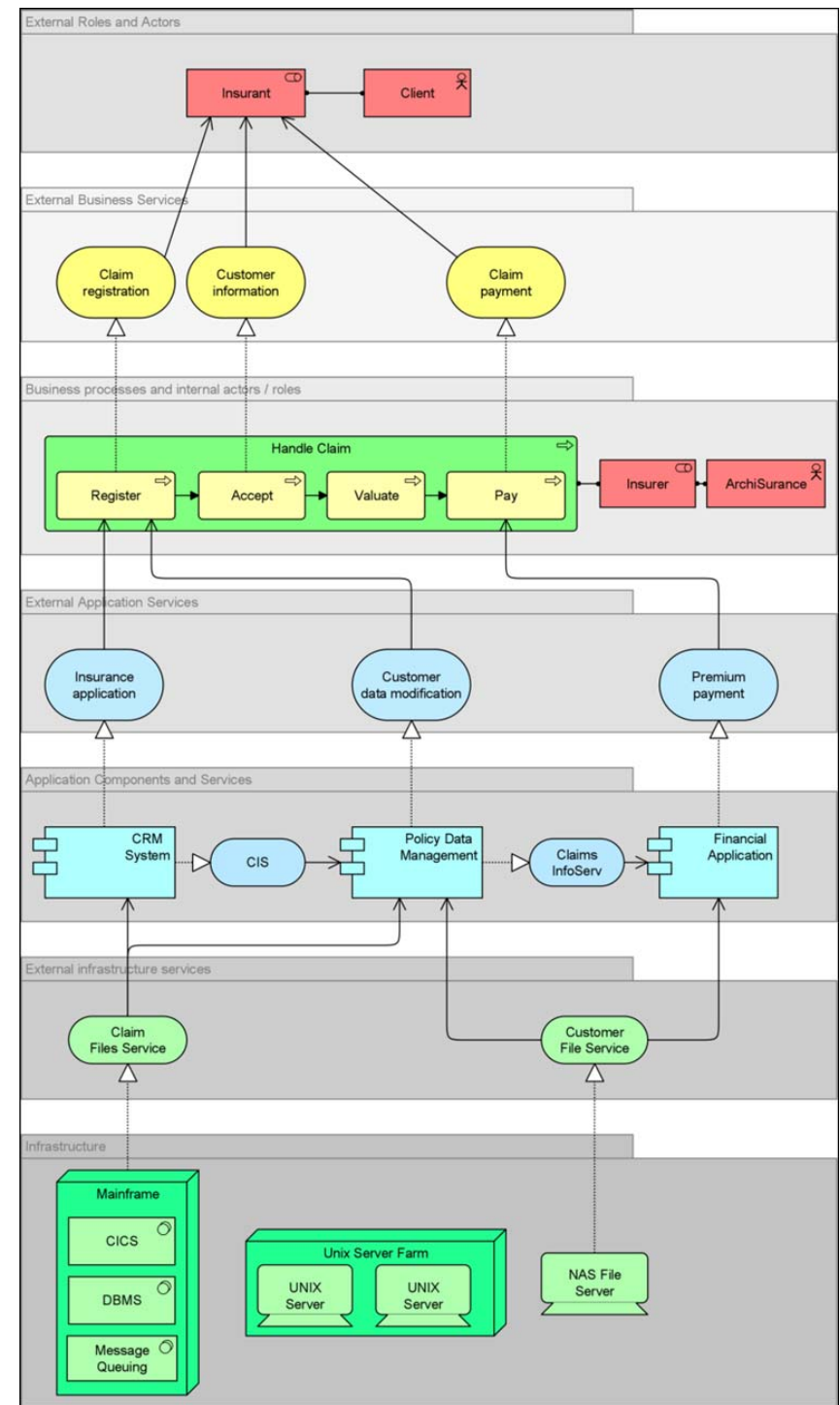

Landscape Map Viewpoint

A landscape map is a matrix that represents a three-dimensional coordinate system that represents architectural relations. In practice, often dimensions are chosen from different architectural domains; for instance, business functions, application components, and products. A landscape map uses the ArchiMate concepts, but not the standard *notation* of these concepts..

Landscape Map Viewpoint	
Stakeholders	Enterprise architects, top managers: CEO, CIO
Concerns	Readability, management and reduction of complexity, comparison of alternatives
Purpose	Deciding
Abstraction Level	Overview
Layer	Business layer, application layer, technology layer (see also Figure 4)
Aspects	Information, behavior, structure (see also Figure 4)

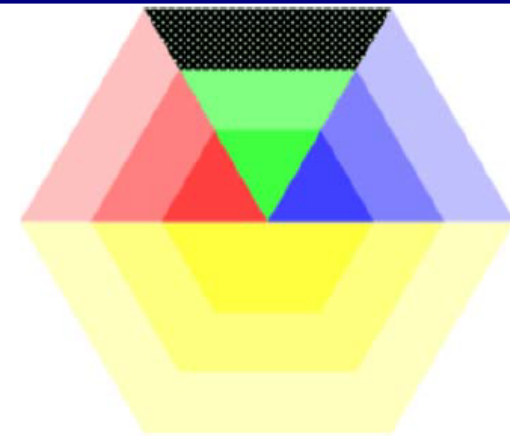

Concepts and Relationships: **all**

Example of a Model from the Landscape Map Viewpoint

